

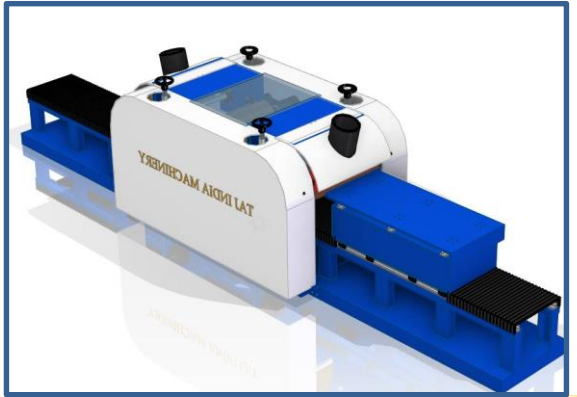

DESIGNED
AND
DEVELOPED
IN INDIA

ISO 9001:2015

Information Book 2024

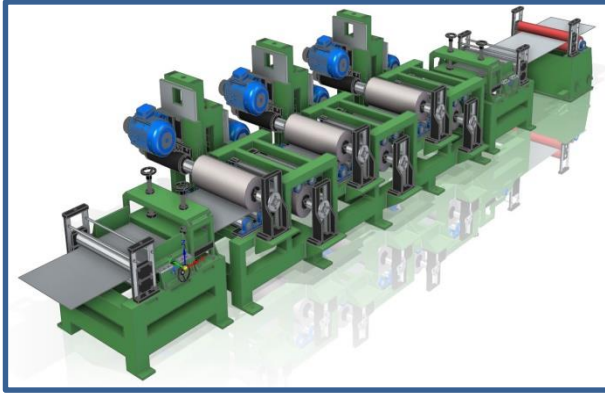

TAJ
TAJ INDIA MACHINERY



TAJ

About us

Welcome



Director

TAJ established in the year 2000, as well known as Manufacturer supplier and exporters, of Various products and seniors such as semi-automatic cutlery Polishing machine, Auto. Lancer Machine ,SS sheet Polishing machine, Kitchenware polishing Machine & vibrator polishing machine. Heavy duty and professional.

Today

TAJ stands as recognized brand's in its line of activities. Since its inception the company has grown manifold in its operations and performance, mainly because of its commitment to quality as in responding to market need & with innovative and value added products TAJ holds the major share at the Indian market with its products being exported to over 5 countries around the world besides being OEM supplier to many international brands.



Quality Policy



Quality culture runs into every segment of TAJ's working supported of more than so highly qualified professional engineers and dedicated workers whose devotion and dedication has become Constant a TAJ Success TAJ believes that quality the Life line of every business and its committed to satisfy its customers by manufacturing and supplying its products to their satisfaction first time and every time with continuous up gradation in the Effectiveness the quality management system.

Who we are ?

The success any industrial organisation closely Parallels its ability to meet the needs a the TAJ INDIA MACHINERY is an outstanding example of this. Through its consistent forts to develop the kind of machine the industrials consumer Wants the Company today holds a position of leadership in the polishing machine manufacturing plants etc.

TAJ is recognized as leader in auto Polishing and cutlery polishing machine Manufacturing plant industry due to its long a story of innovation, which has created major new categories of products expansion into these new products field was the results of a long term and range planning and development programs. Tech campus intention to continually produce innovative new products which may be need today changing.

Taj India Machinery is Delhi, India based firm, engaged in offering a comprehensive series of products. Experts employ the advanced technique to develop these products. In addition, our easy payment options, transparent business dealings, right trade strategy have empowered us in accomplishing.

Some other features:

- + Wide distribution network
- + Safe delivery
- + Cost effective prices
- + Low cost with high quality



CHOOSE YOUR BEST QUALITY MACHINE

TI-AML-2

[Automatic 2 Head Abrasive Belt Grading Machine]

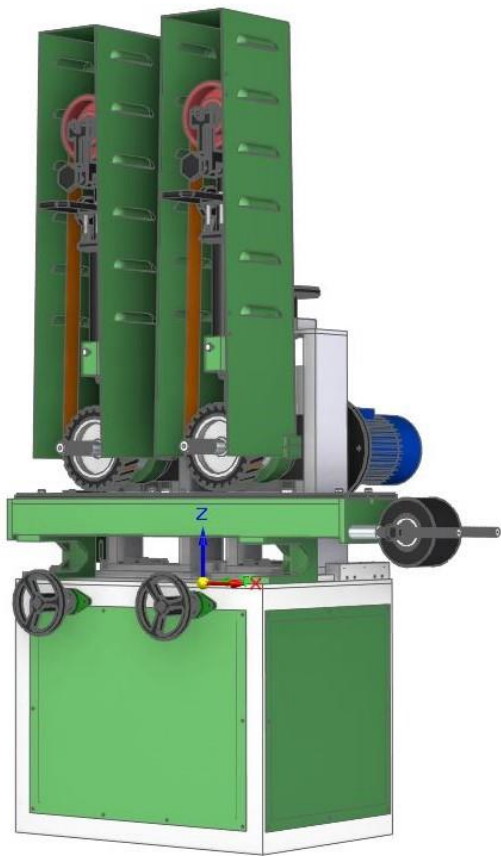

Special Feature:-

- * Abrasive Belt
- * Canver Belt
- * Rubber Contact Wheel
- * Main Motors
- * Gear Motor
- * Machine size

- 50mm x 2000mm
- 100mm x 3000mm
- O.D 200mm x 50 To 150mm
- 3 HP to 5 HP x 2 Motors
- 1 HP x 1Motor
- 1500x900x1750mm

TI-AML-4

[Automatic 4 Head Abrasive Belt Grading Machine]

Special Feature:-

- * Abrasive Belt
- * Canver Belt
- * Rubber Contact Wheel
- * Main Motors
- * Gear Motor
- * Machine size

- 200mm x 2000mm
- 200mm x 5275mm
- O.D 150mm x 50 To 200mm
- 3 HP to 5 HP x 4 Motors
- 1 HP x 1Motor
- 4800x900x1750mm

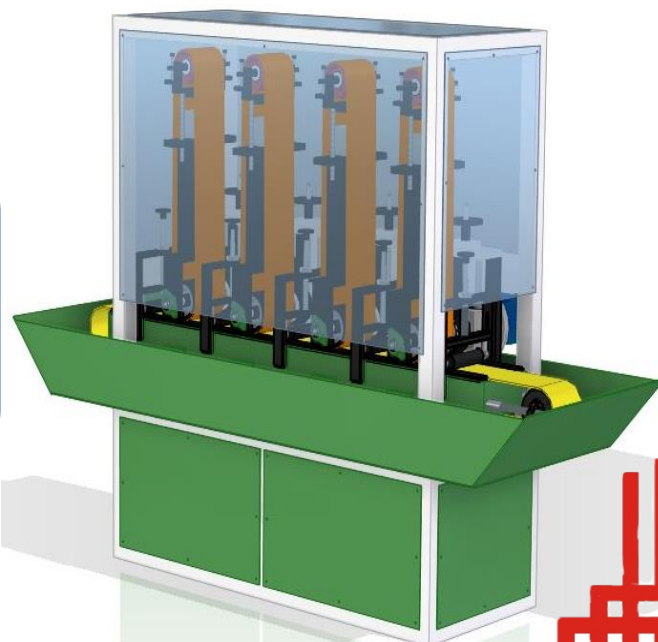

TI-ML-2



Manual lancer Machine

For polishing and Grinding of stainless steel, casting, copper, aluminum black metal, non-ferrous metal, non metallic work piece.

Power	Amri Belt	Contact wheel
5HP	50x3500mm	400x50mm

TI-KN-3

Malty Head Counter Machine



This is a malty head counter machine. this machine use for drilling / Chamfering. No matter what the material is.

Power	Drilling Size.	Spindle
2HP	14mm	3





Manual Polisher

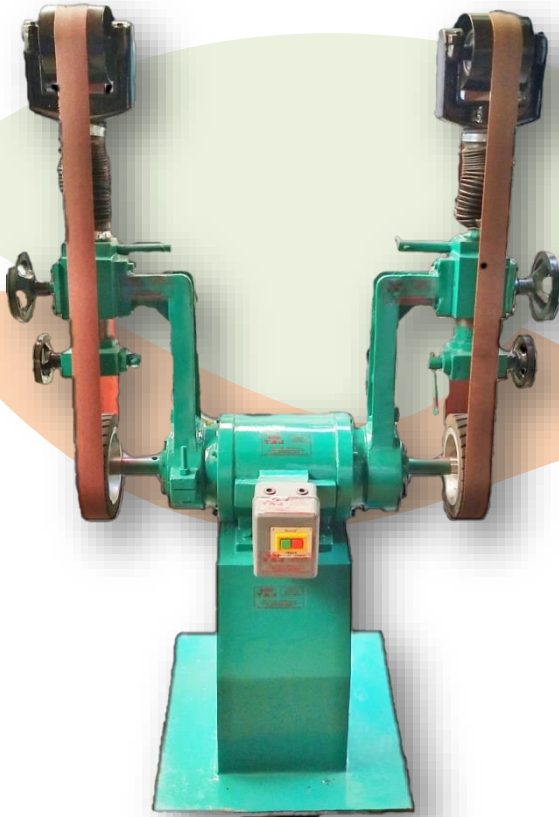

2 HP Belt Grinding Machine
(Double Ended)



2 HP Belt Grinding Machine
(Single Ended)

Application:-

Use for Grinding & Polishing of Arc and Flat Product Such as Steel, Brass, Aluminum, Iron. Available 2 to 7.5 HP and Phase Versatile like 2 and 3 Phase and 5 for manual polisher maximum power 7.5 HP

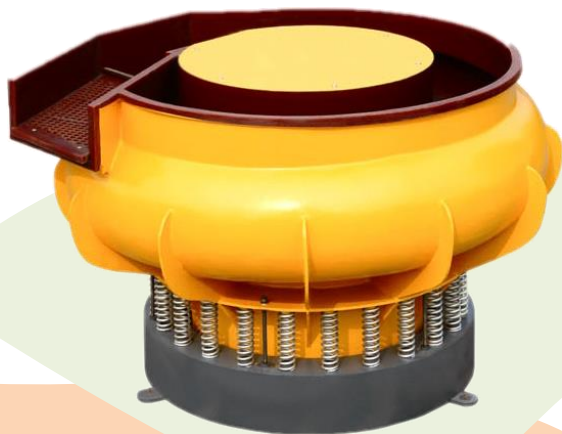

Industrial Vibro Polishing Machine
Capacity 150x1200 Liters
TI-600



Round Pipe Polishing Machine
TI-PPM-2



Square Pipe Polishing Machine
TI-ATPMH-28

Application:-

Recommended for square & round pipe polishing and grinding such as Steel, Aluminium, Iron, Brass etc. And by this machine we can polish and grinding of round & square polishing of pipes. Vibro machine use for small hardware products such as small tools.





The Automatic Hinges polishing solutions SEMI-AUTOMATIC POLISHING MACHINE

TI-AMPA-2

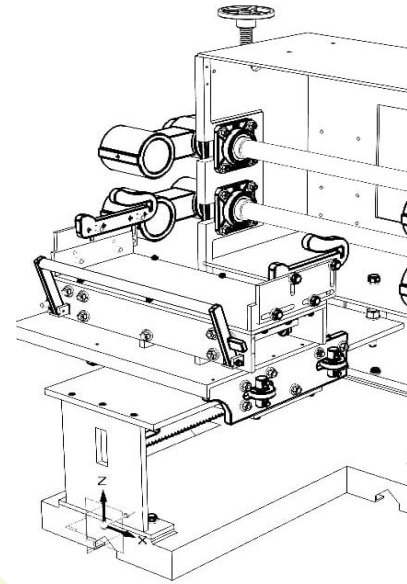
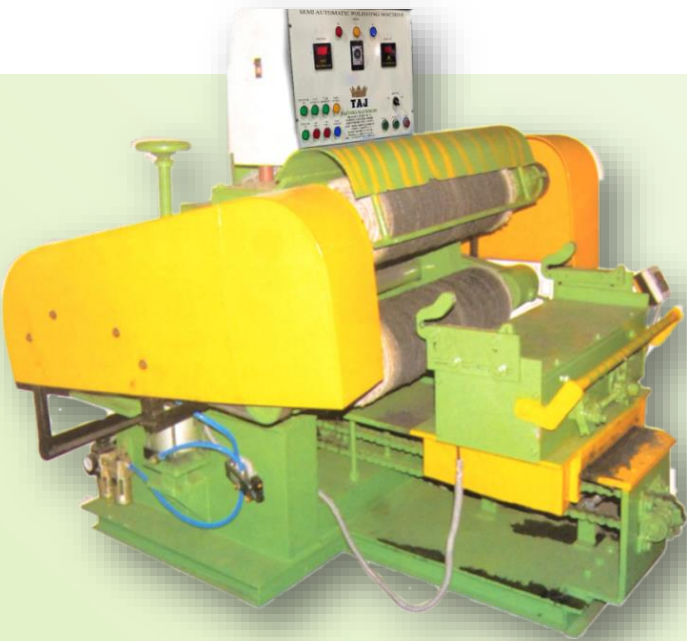

Suitable for polishing & grinding of all kinds hardware products like as SS bathroom jali, AL drops, Hinges, tower bolts, bathroom fitting & many more etc. polishing and grinding

TI-AMPSH-1



Model No	Spindle	Machine Power	Working Area
TI-AMPA-2	Double	15.75 HP	580x400mm
TI-AMPSH-1	Single	8.25 HP	500x400mm





TI-AMP-2

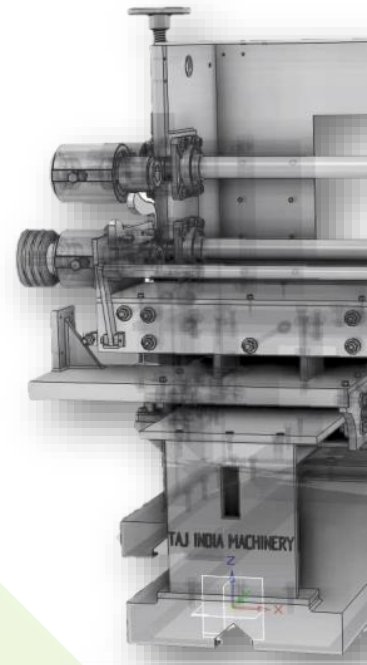

TI-AMPC-2

Suitable for all kinds flat Arc Surface grinding and polishing such as SS Spoon, forks, deaget spoon finishing like mate, mirror, and glossy like that.

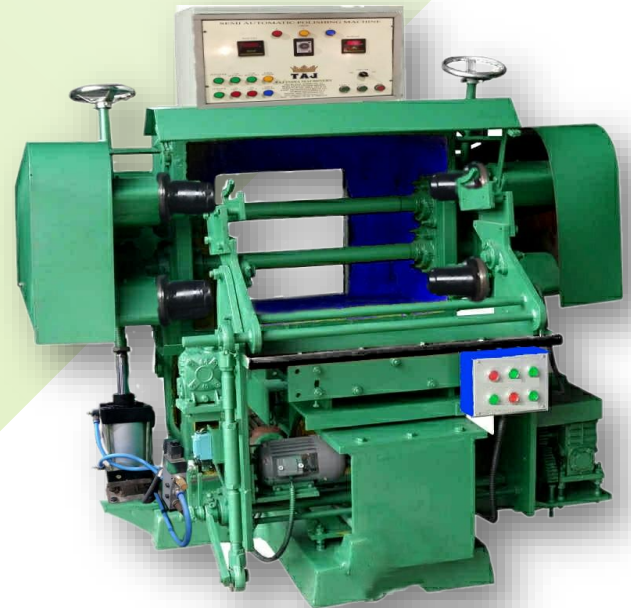

Model No	Spindle	Machine Power	Working Area
TI-AMP-2	Double	15.75 HP	580x400mm
TI-AMPC-2	Double	15.75 HP	600x200mm

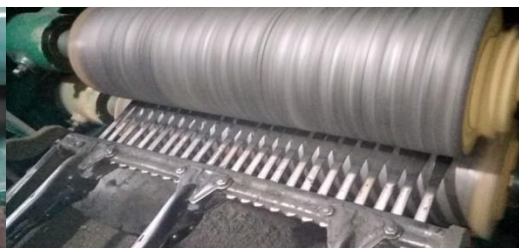

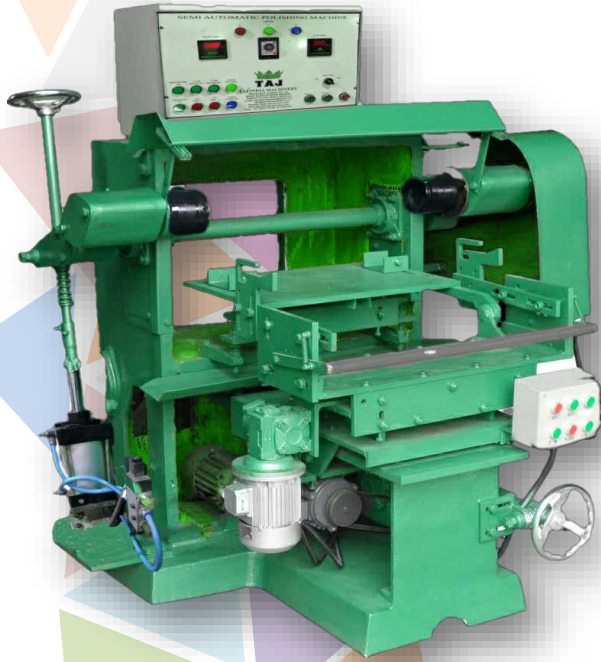

TI-AMPC-1



TI-PEG-1301

TI-PEG-1301 & All

This machine is suitable for the grinding and polishing of SS Forks and Spoons Curve edges in former process and can also polish the intrados and periphery of SS cutlery by installing different polishing materials.

For polishing and plane burnishing of stainless steel plate black metal, non-furious metal, aluminum plate polishing the rags, edge, oxide, skin, removed by the sheet polishing machine and finishing as glossy mate mirror etc.



TI-AMPSS-2/6

Model No	Spindle	Machine Power	Working Area
TI-AMPC-1	Single	8.25 HP	580x400mm
TI-AMPSS-2/6	Single	15.75 HP	600x2400mm

This is power press machine available up to 100 ton from 5 ton capacity to use any kind of jobs in various industries. We design special sizes and stock as per need. The power press fabricated with mild steel body and available in C and H type frame.

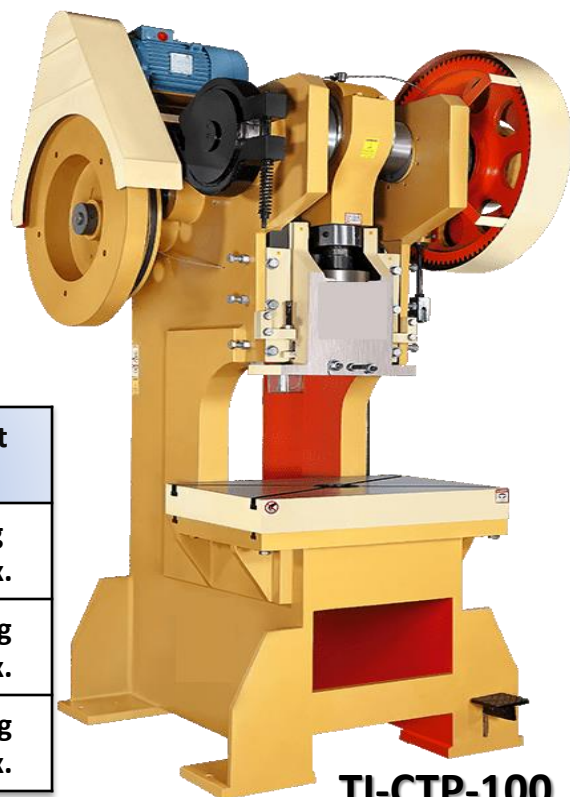

TI-CTP-100

Model No	Tonnage	Stroke Length	Power	Fly wheel	Weight
CTP-10	10 Ton	51 mm	1 HP	435 mm	525 kg Approx.
CTP-20	20 Ton	76 mm	2 HP	560 mm	1020 kg Approx.
CTP-30	30 Ton	76 mm	3 HP	650 mm	1300 kg Approx.

Standard Equipment:-

- * Flywheel & Gear Guard
- * Electrical Motor, Starter & V-Belt
- * Motor Pulley
- * Oil Cups & Self- Lubrication System
- * Knock Out System (For 20 Ton & Above)
- * Slide Adj. Spanner
- * A Pair of Die Clamp

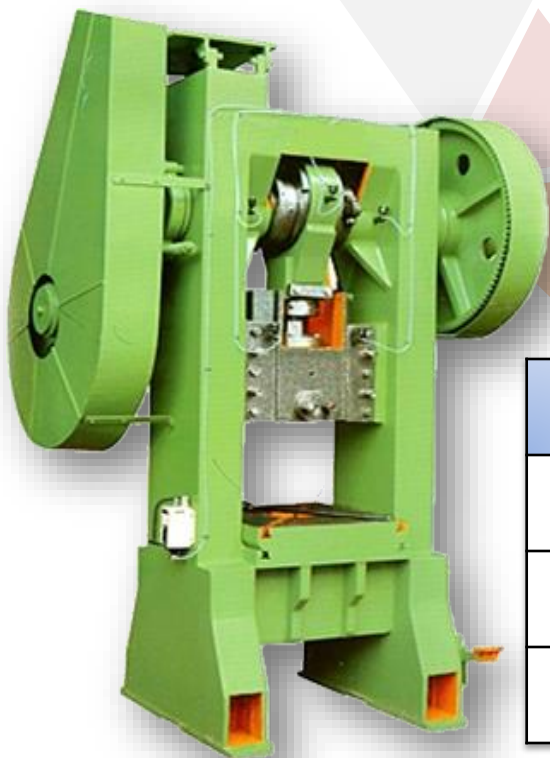

TI-HTP-250

Model No	Tonnage	Stroke Length	Power	Fly wheel	Weight
HTP-50	50 Ton	102 mm	5 HP	660 mm	2250 kg Approx.
HTP-75	75 Ton	115 mm	7.5 HP	812 mm	3500 kg Approx.
HTP-100	100 Ton	127 mm	10 HP	914 mm	4500 kg Approx.



AUTOMATIC POLISHING MACHINE

The Automatic Utensils Polishing Machine



TI-RND/PM-2

1. This Machine is PLC control. In this machine, you can do polishing and grading from inside and outside the utensils items.
2. Suitable Polishing Materials: Grinding wheel, sisal wheel, cloth wheel.
3. Use: Suitable for





AUTOMATIC POLISHING MACHINE

The Automatic Rotary Polishing Machine

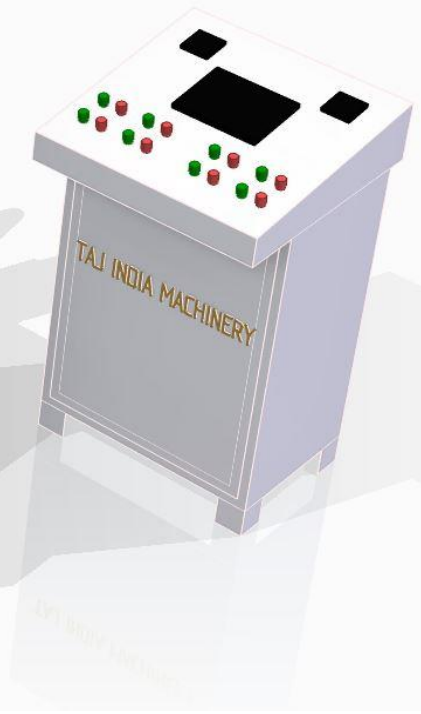
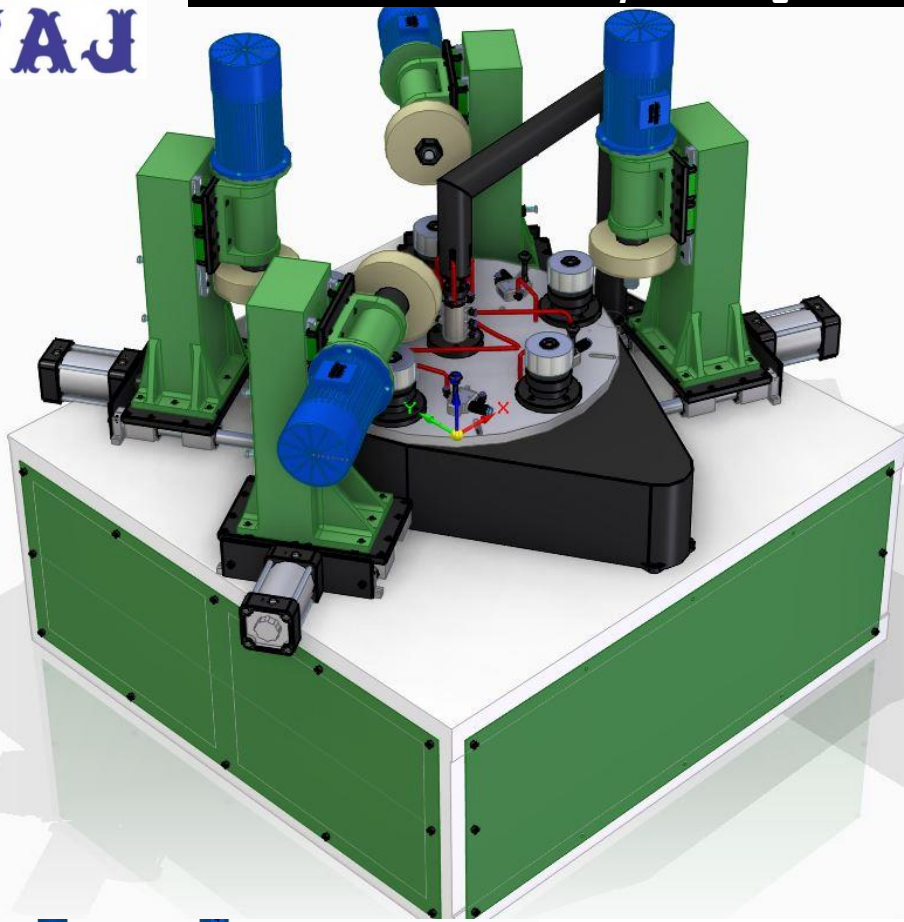

TIM-2023/RTRY-4AIR

1. It is suitable for Polishing of ROUND Products, Material, Stainless Sheet, Copper, Aluminum, Iron, Alloy etc.
2. Suitable Polishing Materials: Grinding wheel, sisal wheel, cloth wheel, wind wheel, nylon wheel, thousand leaf wheel.
3. Use: Suitable for all type of round. products.





AUTOMATIC GRINDING MACHINE

The Automatic Hinges L Side Grinding Machine

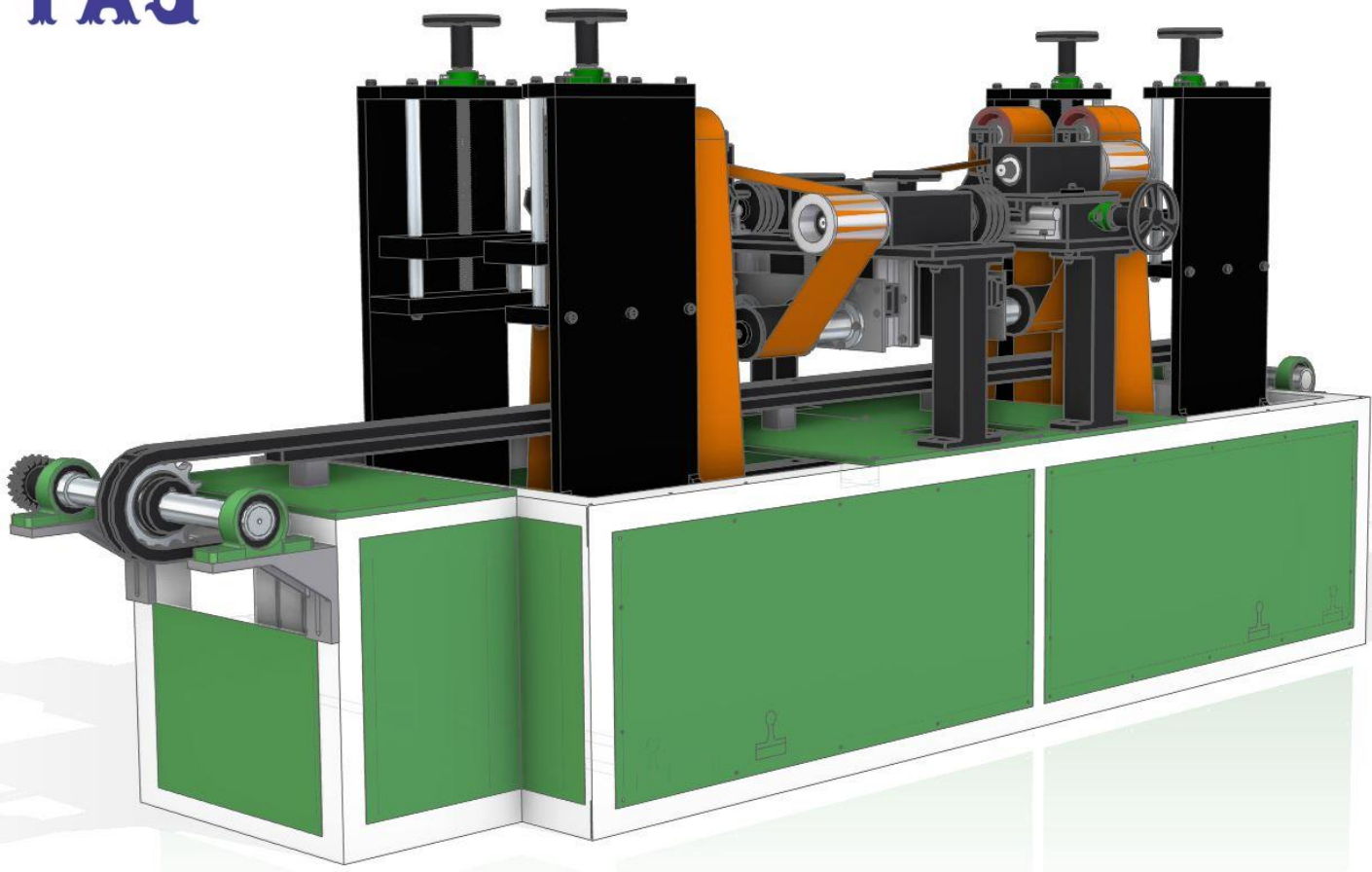

TI-HG/SGM-4

1. It is suitable for Polishing of HINGES, DOOR HANDALS and FLAT Products, Material, Stainless Sheet, Copper, Aluminum, Iron, Alloy etc.
2. Suitable Polishing Materials: Grinding wheel, sisal wheel, cloth wheel, wind wheel, nylon wheel, thousand leaf wheel.
3. Use: Suitable for furniture, hardware items and other industries.

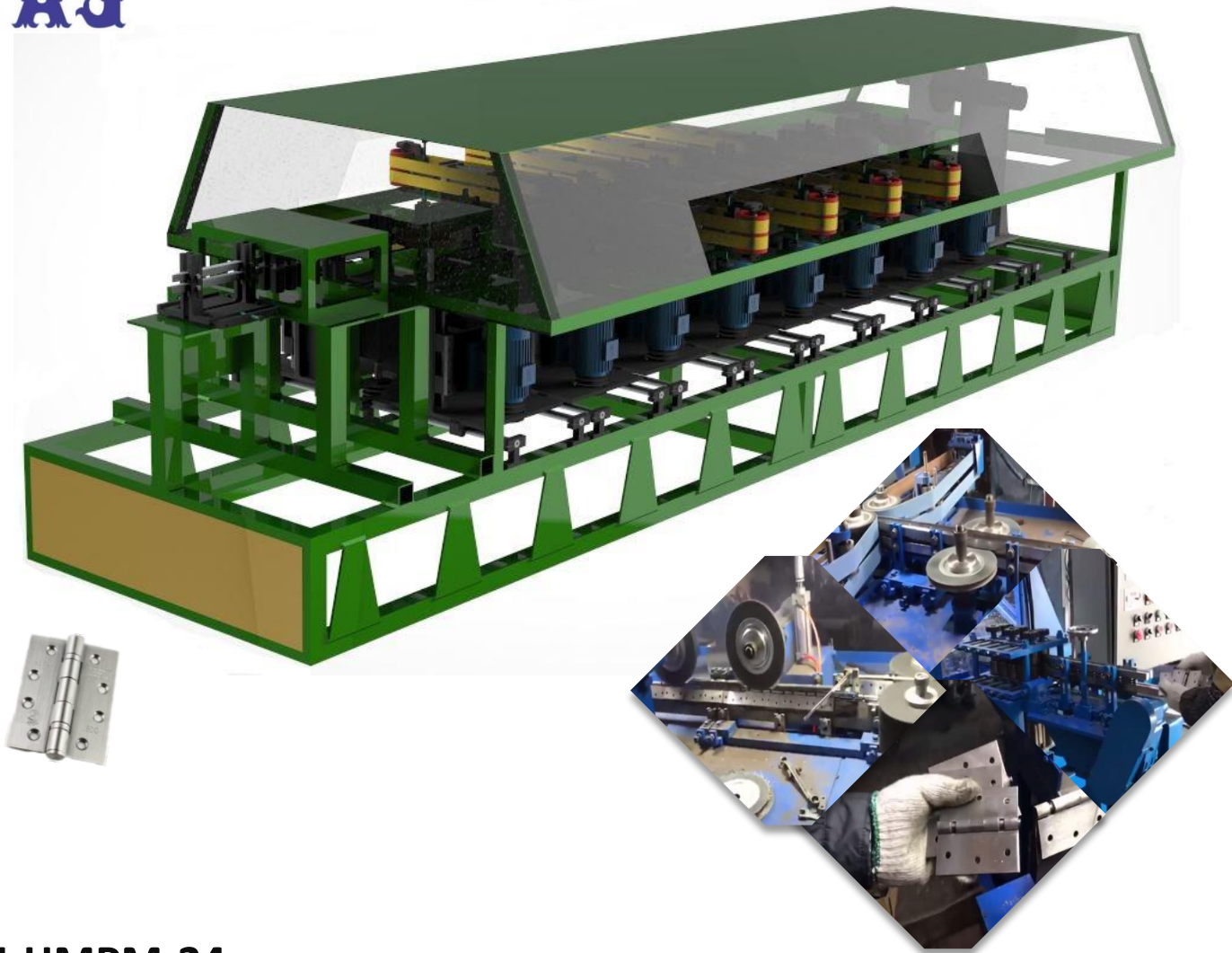

TI-HMPM-24

1. It is suitable for Polishing of any size of hinges, Material Stainless Steel etc.
2. Suitable Polishing Materials: Grinding wheel, non woman, abrasive belt.
3. Use: Suitable for hinges.

Model No	Machine size	Machine Power	Working Area
TI-HMPM-24	6000x2000x1650MM	95 HP	3" To 6"

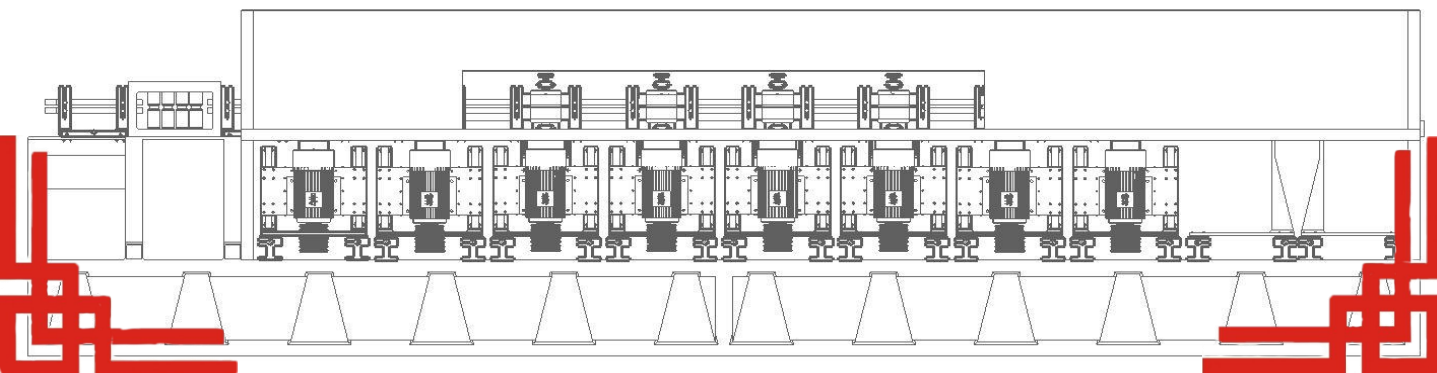



AUTOMATIC POLISHING MACHINE

The Automatic sheet polishing/Grinding machine

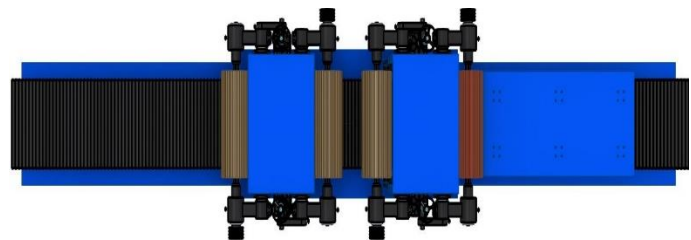
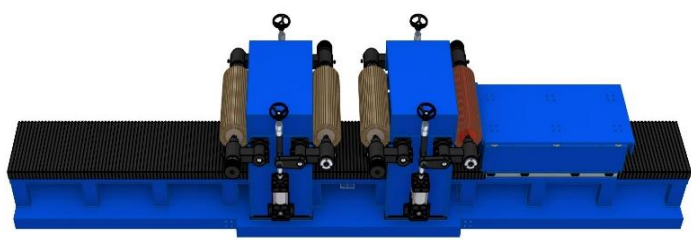
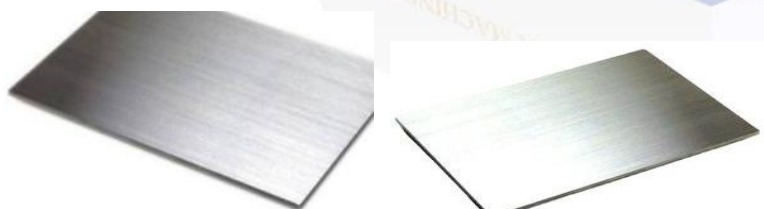
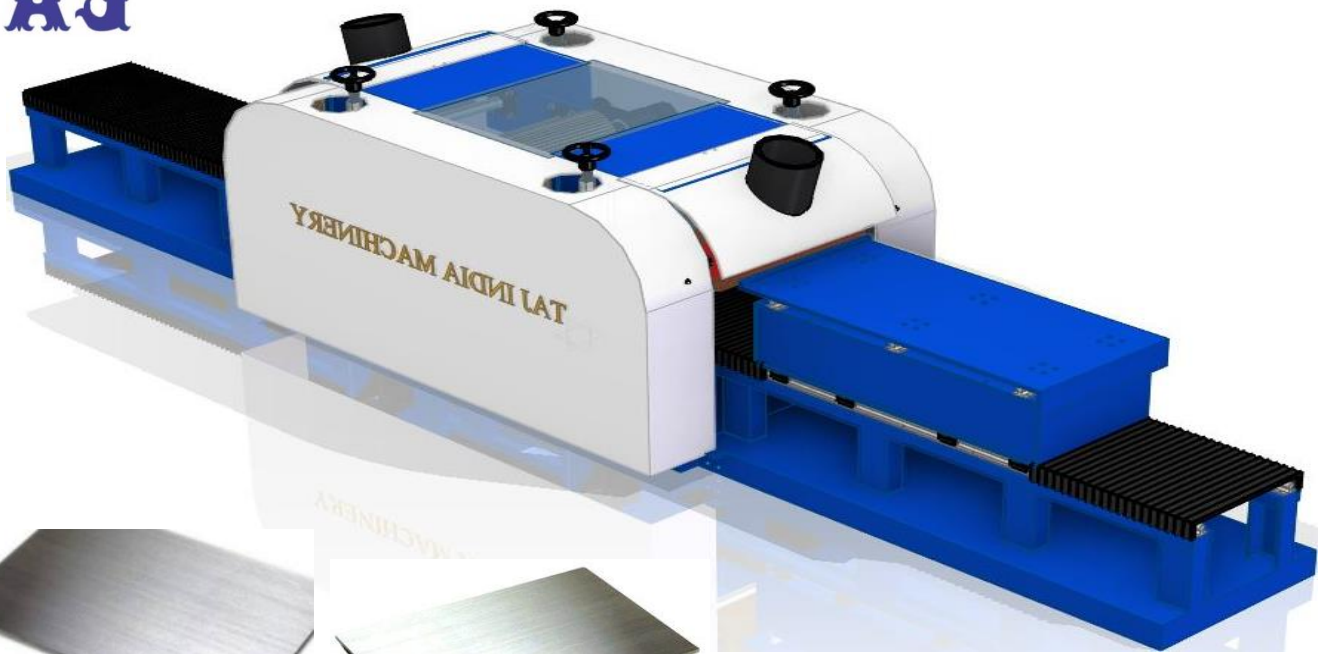

TI-ABPSH-4

Sheet grinding/polishing machine (wet Or dry type) uses grinding oil or emulsion as a media to achieve fine and sing grinding effect on either hot or cold-rolled stainless steel Sheets.

The machine is designed to get finishing.

No.3 (coarse finishing, abrasive grain from G60 to G150

No.4 (Fine finishing, most popular, abrasive grain from G180 or above)

HL Finishing (Hairline finishing, Characterized by smooth and long line)

Model No	Spindle	Machine Power	Working Area
TI-ABPSH-4	FOUR	33 HP	610x2500MM

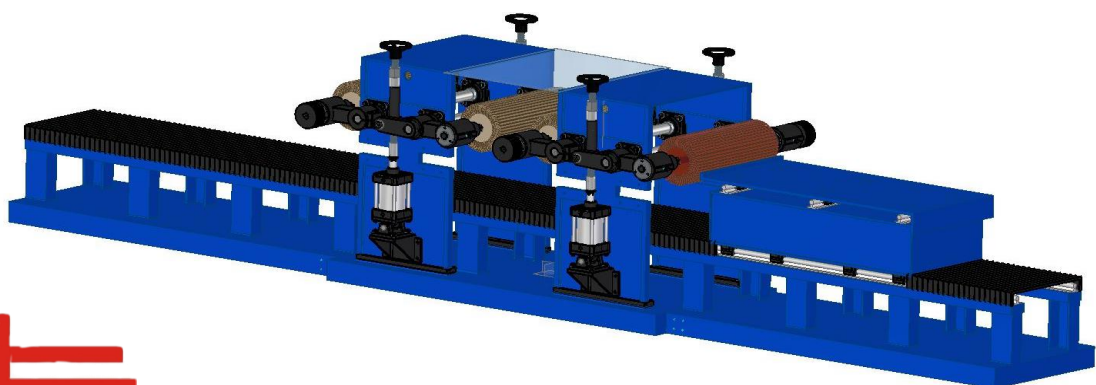

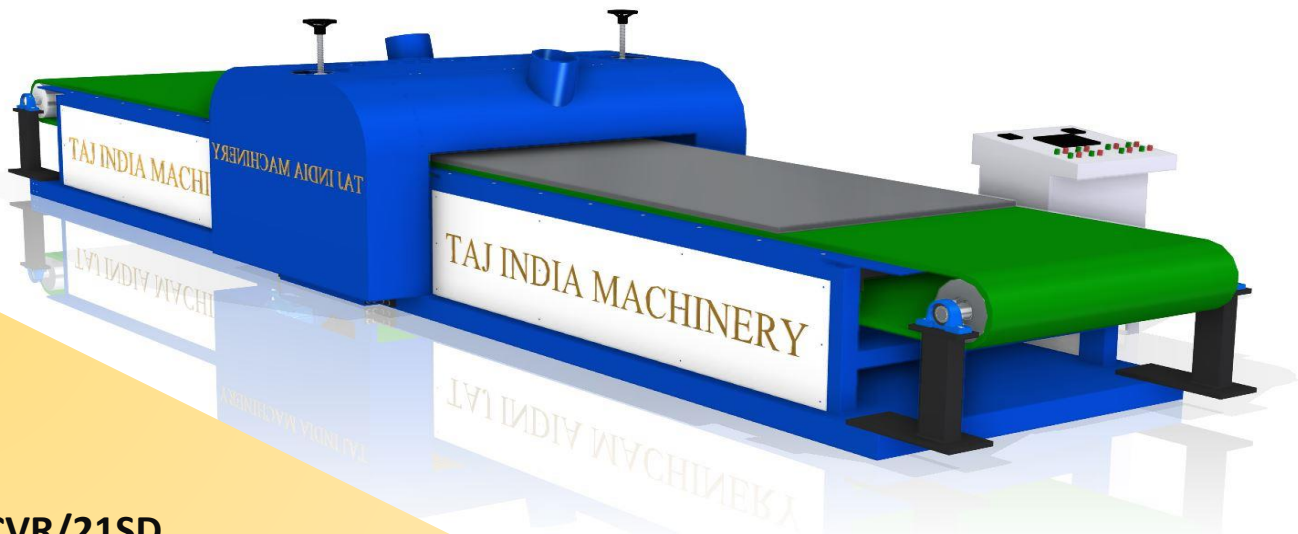

TI-CVR/21SD

This machine is suitable for the grinding and polishing of SS, MS, brass, aluminum sheet Polishing Machine.

The offer an endless range of finishing effects in terms of brightness and finishing easy to Achieved.

Matt, Hair-line, satin, no 4, 2 finish, Mirror finishing, Glossy Finishing Machine etc.

Polishing is a value-added operation in stainless steel sheet. The highest possible Degree of surface finish is usually desirable, for two quite distinct reasons, aesthetic and Functional points of view.

Model No	TI-CVR/21SD
Power	17 HP/12.67KW
Spindle	DOUBLE
Working size	1200 MM
Gear box	TAJ MAKE
Wheel size	200MM X 1220MM
WEIGHT	4.5 TON

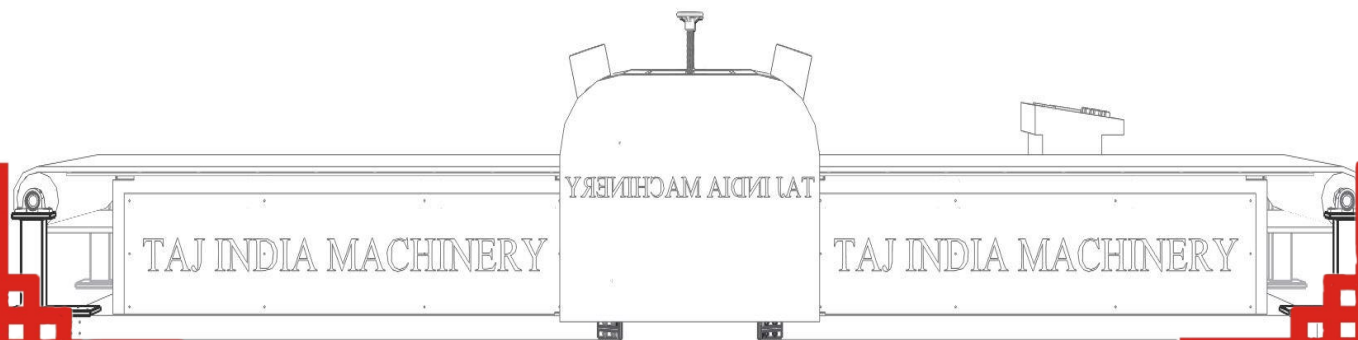

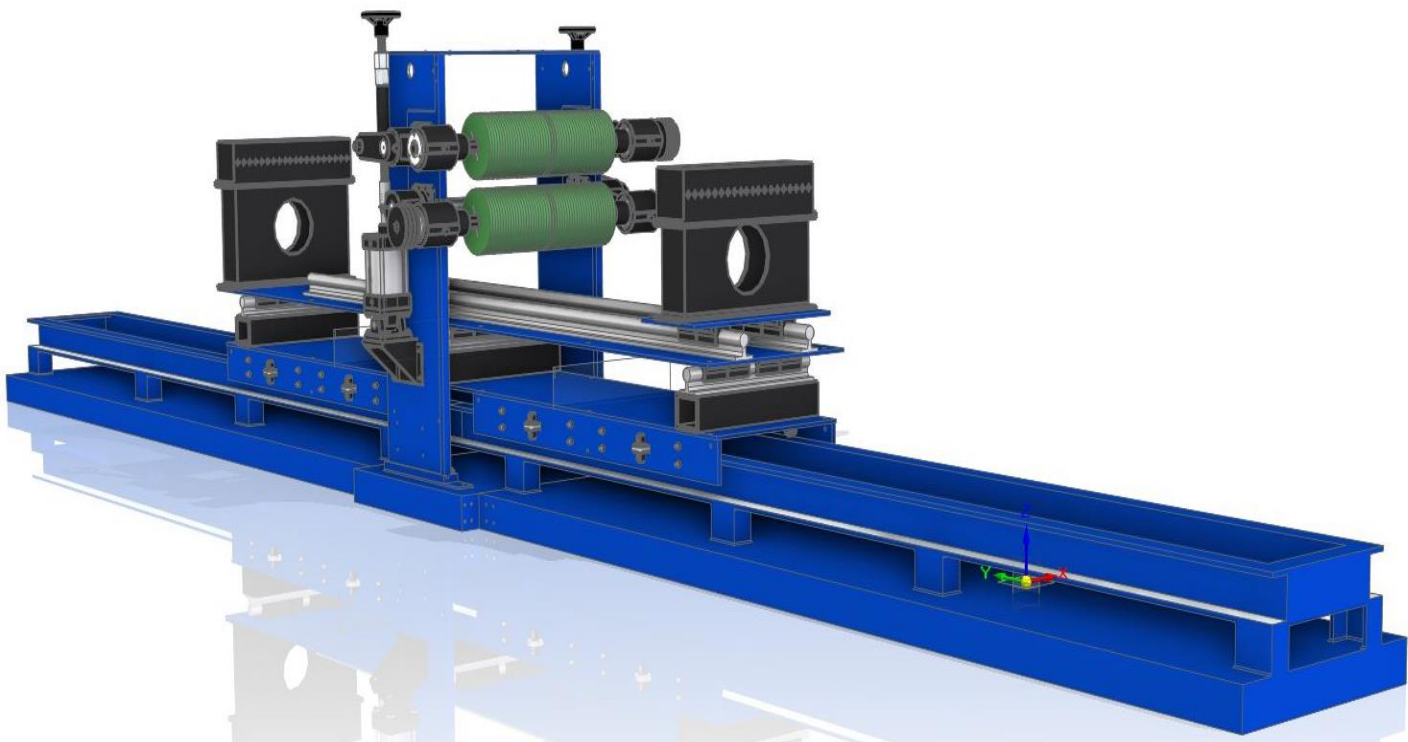

TI-AB/SPM-2

1. It is suitable for Polishing of ROUND, SQUARE, HEXAGONAL, and FLAT Products, Material, Stainless Sheet, Copper, Aluminum, Iron, Alloy etc.
2. Suitable Polishing Materials: Grinding wheel, sisal wheel, cloth wheel, wind wheel, nylon wheel, thousand leaf wheel.
3. Use: Suitable for furniture, sanitary ware, plumbing, stair handrail, display racks, sports equipment, photographic equipment. Fining gear and other industries.



Model No	Spindle	Machine Power	Working Area
TI-AB/SPM-2	Double	25 HP	2600MM

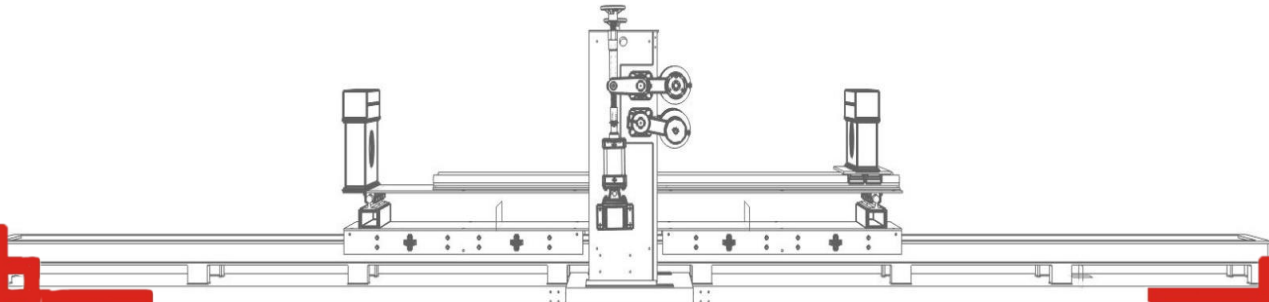



The Automatic SS Coil Polishing Machine

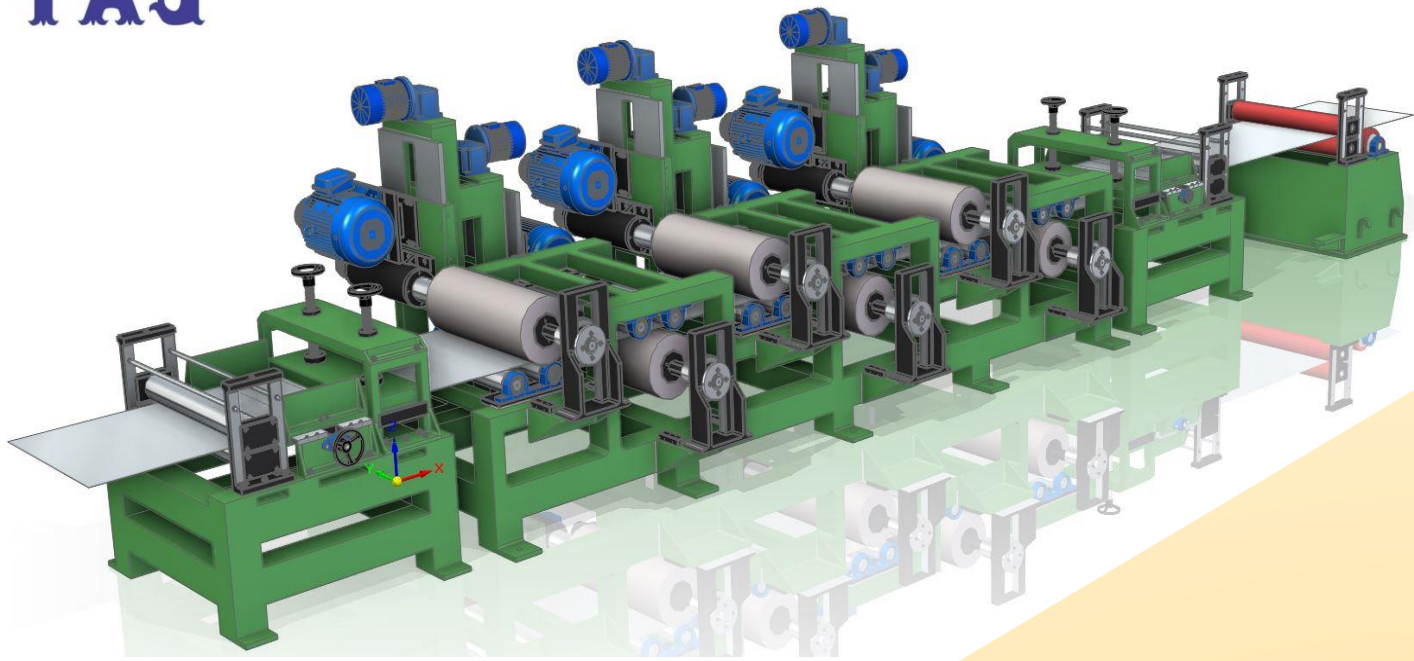

TI-ACPM-16/DOUB

This machine is suitable for the grinding and polishing of SS Coil. With CLENGING and Double side PVC Packing Machine.

The offer an endless range of finishing effects in terms of brightness and finishing easy to Achieved.

Matt, Hair-line, satin, no 4, 2 finish, Mirror finishing, Glossy Finishing Machine etc.

Polishing is a value-added operation in stainless steel sheet and coil. The highest possible Degree of surface finish is usually desirable, for two quite distinct reasons, aesthetic and Functional points of view.



Model No	TI-ACPM-16 DOUB
Power	192 HP/143.174KW
Spindle	16
Working size	800 MM
Gear box	TAJ MAKE
Wheel size	300MM X 800MM
WEIGHT	13 TON

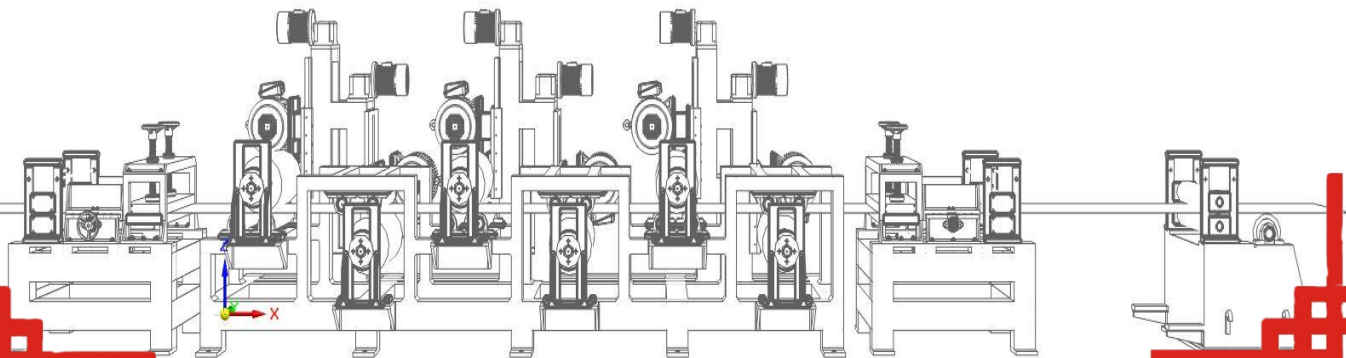

TAJ INDIA MACHINERY

Semi automatic Spoon and Forks Polishing Lain Process

Double spindle

Single spindle

Single spindle

Single spindle

Single spindle

Single spindle



Sisal

Sisal

Sisal

Sisal

Hard Sisal

Sisal

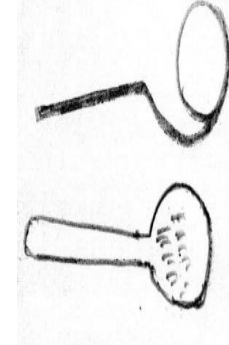
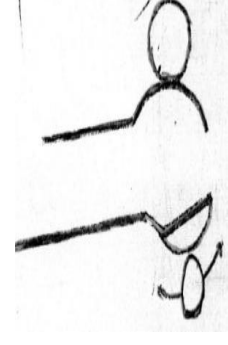
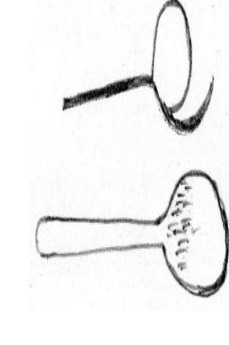
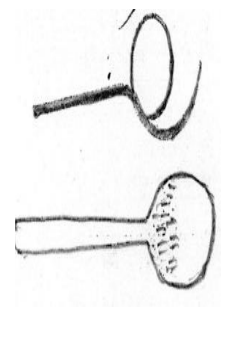
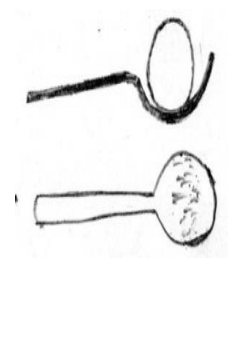
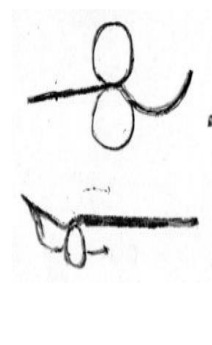

Single spindle

Double spindle

Double spindle

Double spindle

Double spindle

Double spindle



Cotton

Soft Sisal

Cotton

Hard Sisal

Sisal

Cotton

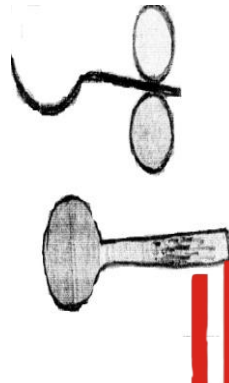
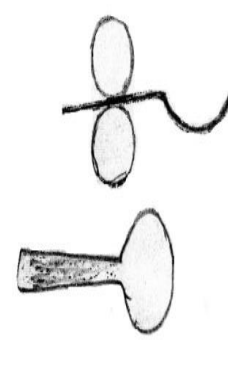
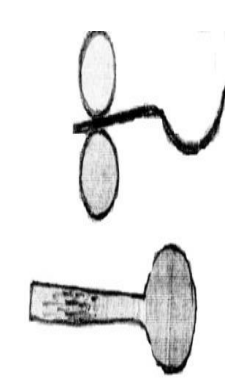
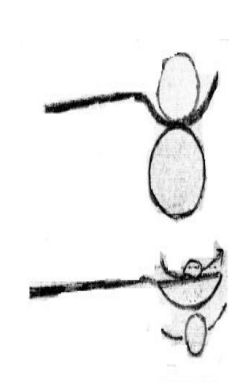
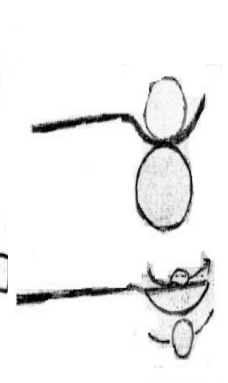
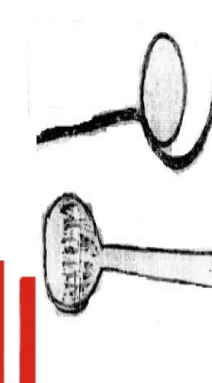



TAJ INDIA MACHINERY

Semi Automatic Hinges Polishing Machines Lain

Double spindle



Grinding (Amri)

Double spindle



Sisal

Double spindle



Soft Sisal

Double spindle



Buff

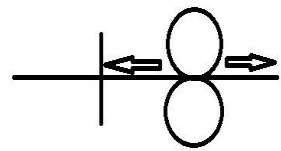
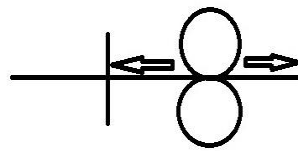
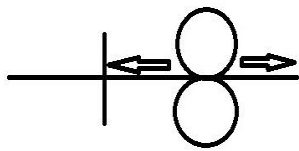
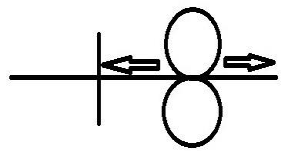

Changing

Double spindle



Grinding (Amri)

Double spindle



Sisal

Double spindle



Soft Sisal

Double spindle



Buff

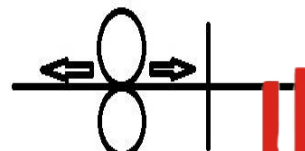
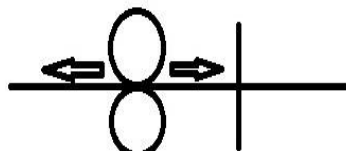
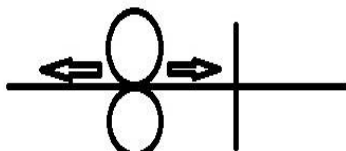
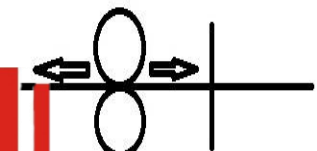



We also deals in flowing:-

Polishing Wheel (PW)

Formed by intercrossing layers of cotton cloth, sewed spirally with cotton thread, these buffs are suitable, for polishing of any accessible flat surface, as a set-up wheel with glue and abrasive emery.

- Sisals
- Cotton Shaan
- Air Flow Buff
- Flap Wheel
- Contact Wheel
- Hangers
- Clips
- Sisals Shafts
- Cotton Shafts
- Air Flow Shafts
- Hinges Grease
- Polishing Waxes Soap
- Abrasive Belts
- Non-Woven

Our Objectives

- ✓ Customer satisfaction
- ✓ Prompt after sales service and solution
- ✓ Innovative and latest technology
- ✓ Quality parts and accessory support

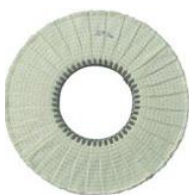
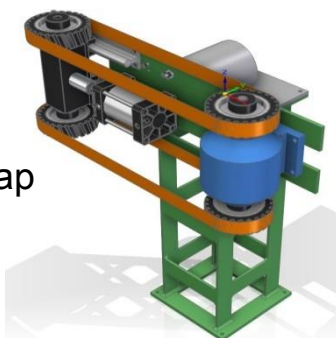

Shinning Bar



AFTER SALES SERVICES

Machine Lifecycle Services :

- + Installation & Commissioning
 - + Upgrade/ Retrofit
 - + Value Added Services
1. Production Support
 2. Maintenance/ Servicing
 3. Annual Maintenance Contracts
 4. Maintenance Audits
 5. Process Optimization
 6. Training for Effective Use of Machine

TECHNICAL SUPPORT

We are not One Day wonder Company. We provide technical support to our customer. We will be here for you always. We make every effort to provide our customers with great products and unparalleled services throughout, which make us stand out from the crowd.

For Service Call Us.
Mr. Tanzeem Ahemad
+91-9718067276
 Email.- tanzeem.tajindia@gmail.com



CERTIFICATIONS

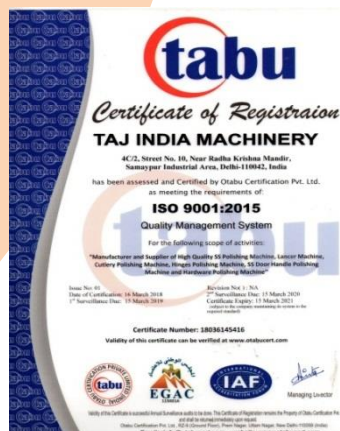

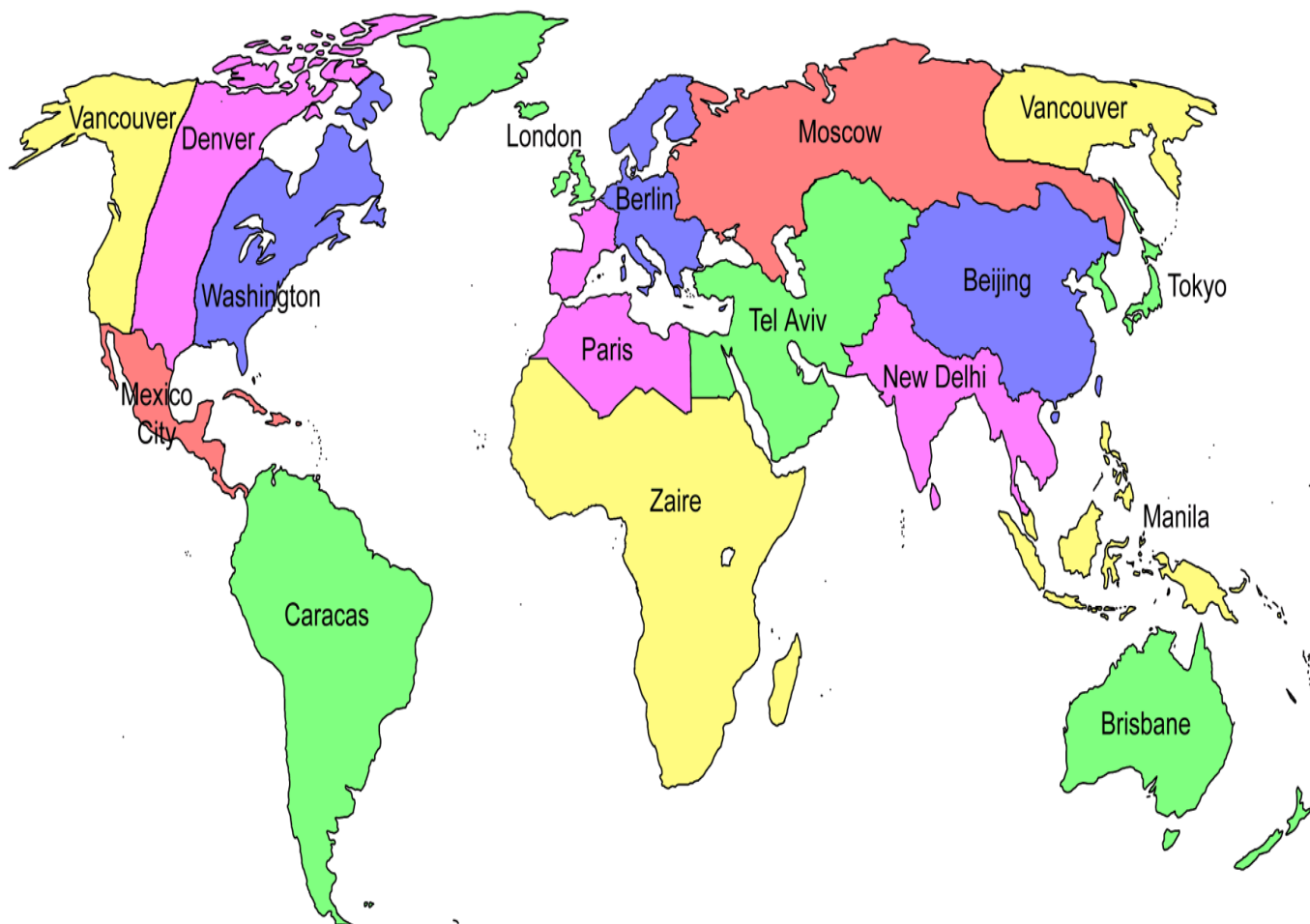

TAJ INDIA MACHINERY

Office/Factory : Plot no. 4C/2 Street no. 10, Near Radha Krishna Mandir, Samaypur Industrial area Delhi-110042

Mobile : +91-9599760205, 9971934089

Email : tajindiamachinery@gmail.com
info@tajpolishingmachinery.com

Website : www.tajindiamachinery.com
www.tajpolishingmachinery.com



Follow us:

